



**Mercury Magnetics**

10050 Remmet Ave. • Chatsworth, CA 91311  
 (818) 998-7791 • FAX (818) 998-7835

info@MercuryMagnetics.com • www.MercuryMagnetics.com

Our products are designed and handmade in So. California, USA • Established in 1954

**FBFVL-P**

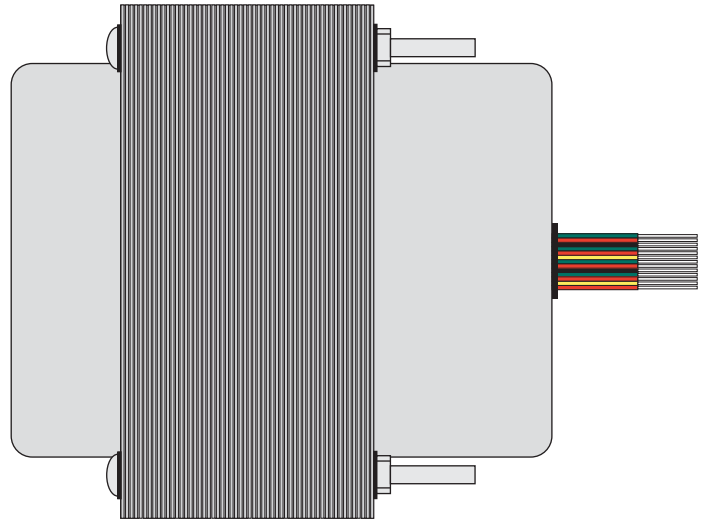
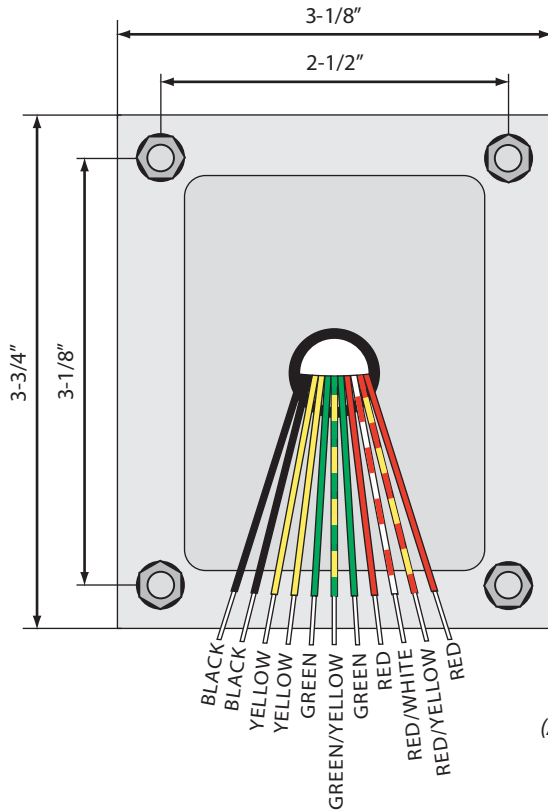

(All dimensions are nominal)

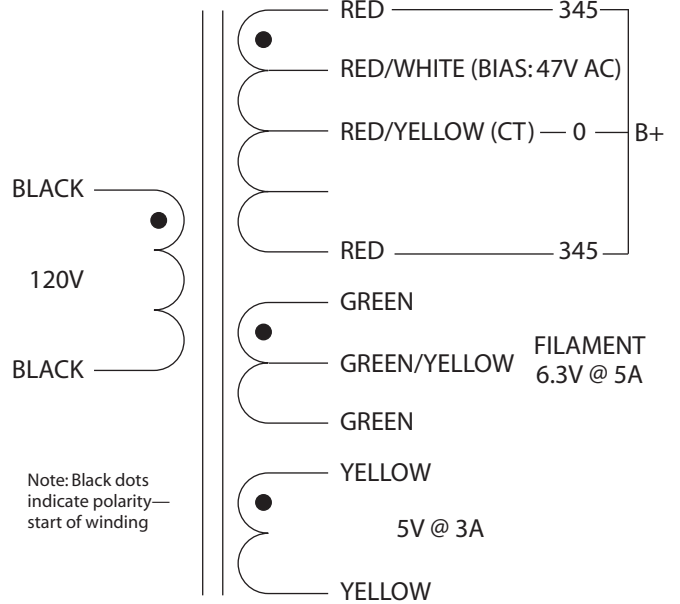
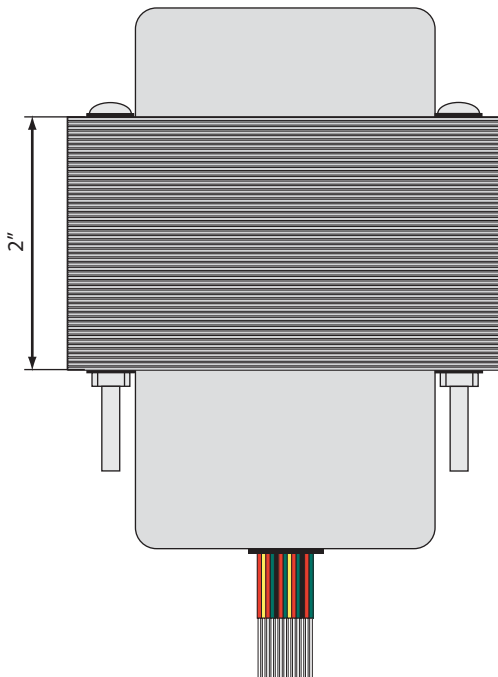

Note: Black dots indicate polarity—start of winding

**PRIMARY**

**SECONDARY**

**Fender Blackface Vibrolux (35–40 watts)**

Origin: Cloned from an original vintage piece manufactured on the 38th week of 1964.

**CLASS:** ToneClone™

**TYPE:** Power Transformer

**PART NO.:** FBFVL-P

**ORIGINAL FENDER PART #:** 125P26A

**MOUNTING:** Flat Mount (standard) other mounting styles available upon request

**VA RATING:** 150

**DATE:** 01-27-06/R10-09-06

**FBFVL-P**